

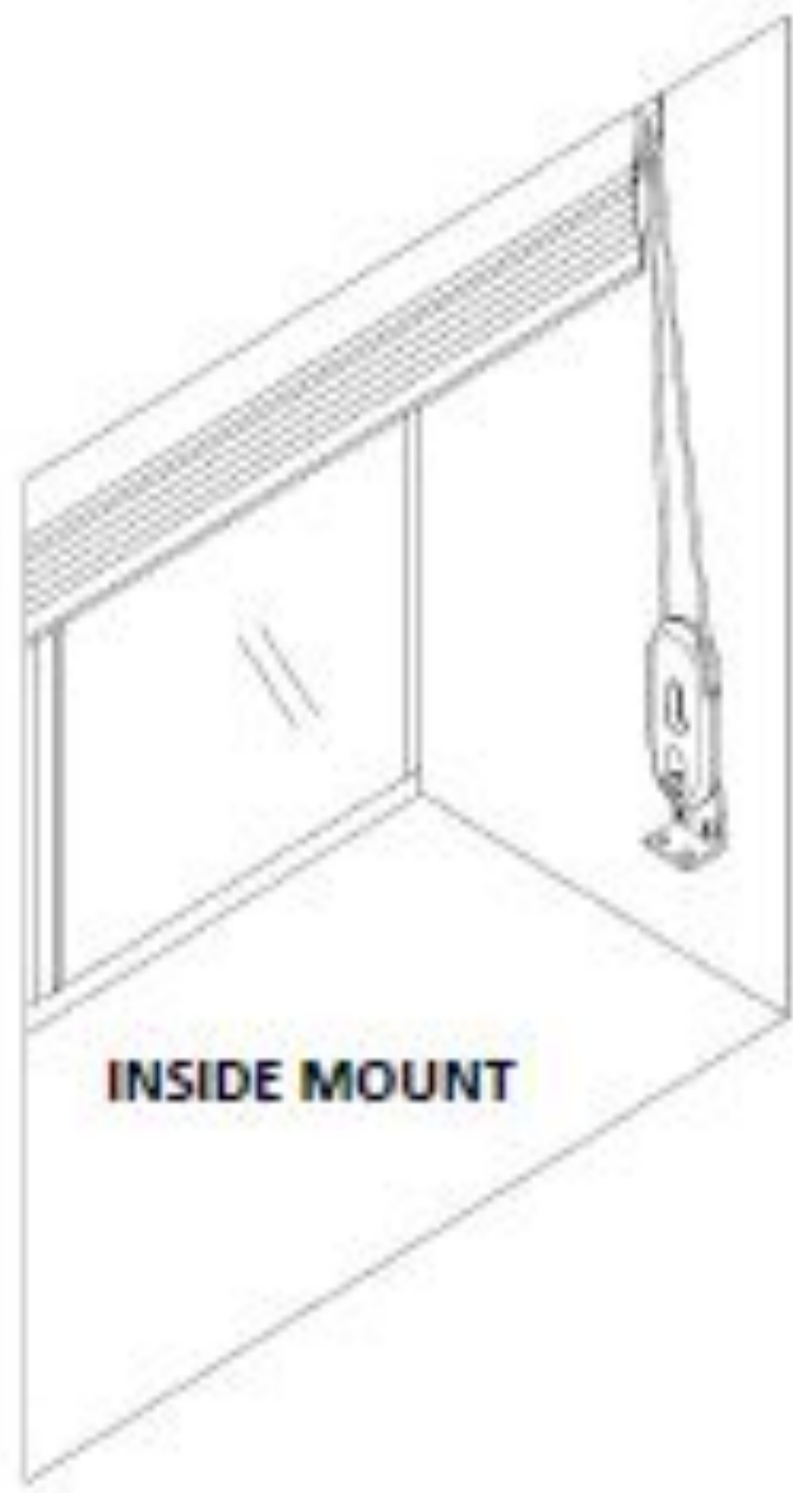





INSTALL THE SAFETY TENSIONER

IMPORTANT-THE CLUTCH CELLULAR SHADE WILL NOT OPERATE WITHOUT THE SAFETY TENSIONER PROPERLY INSTALLED. FOR SAFETY REASONS, THE CORDLOOP MUST BE SECURED TO ENSURE IT IS UNDER TENSION AT ALL TIMES.

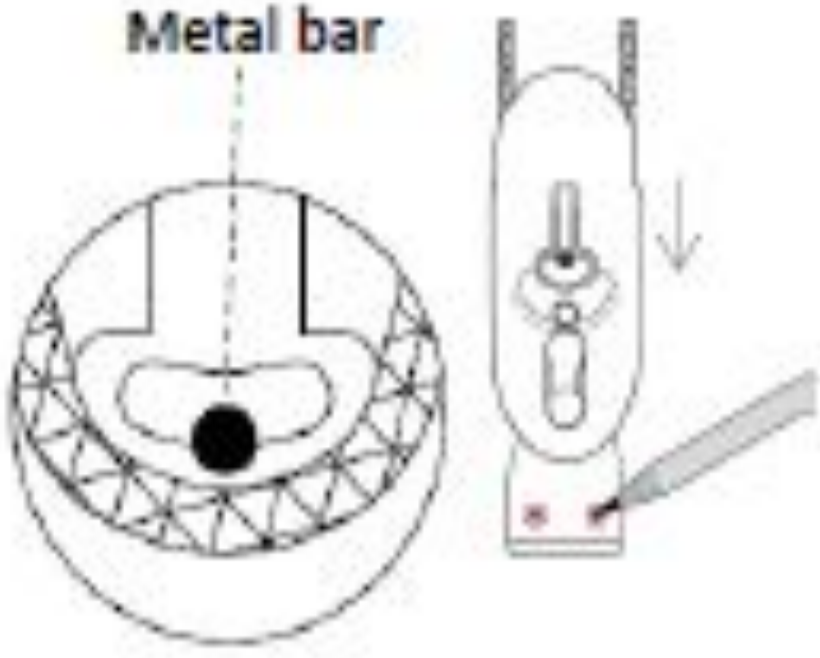

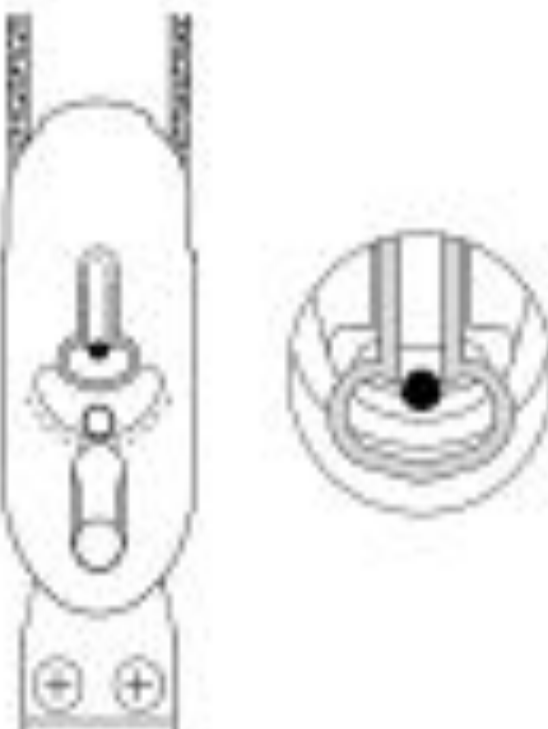
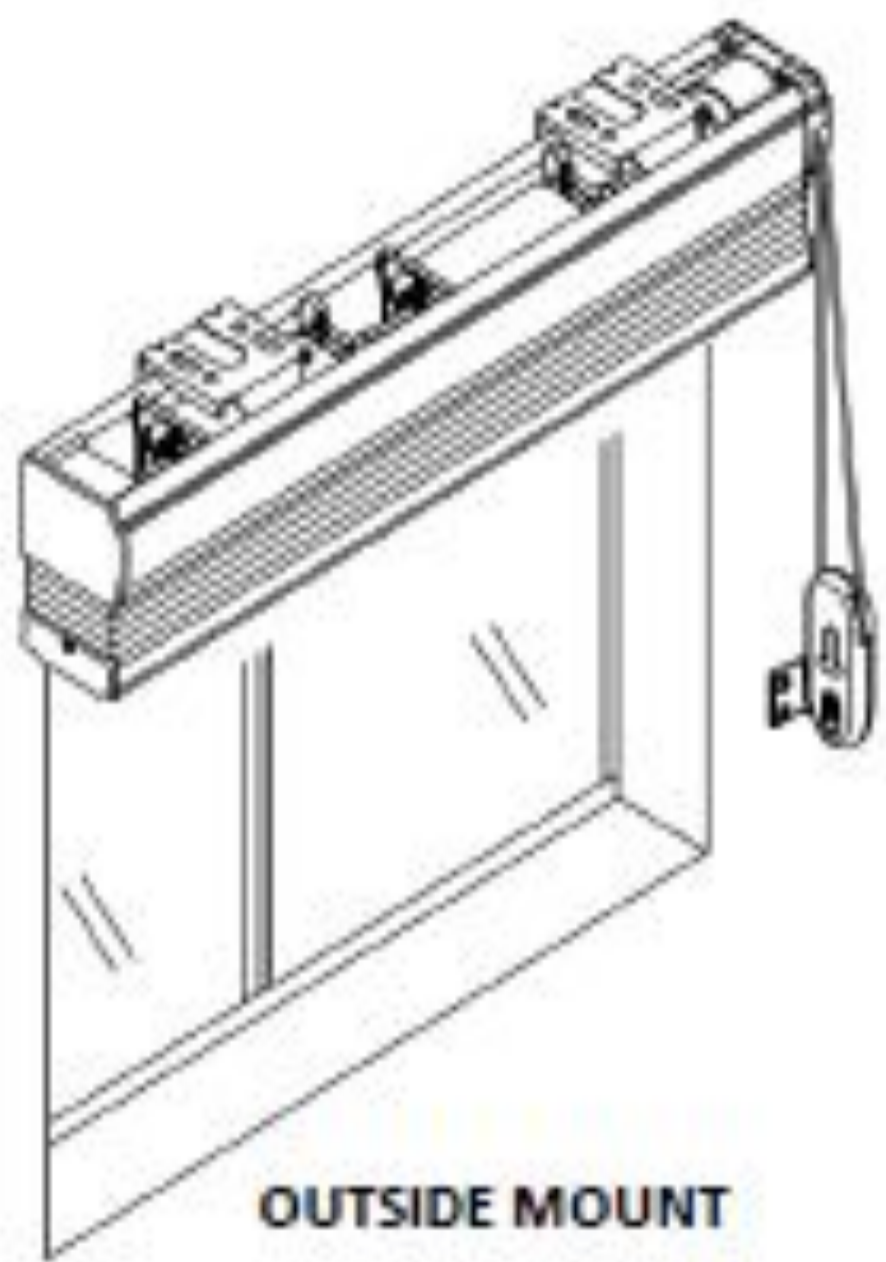
<p>1. Hook the L-bracket to the tensioner.</p> 	<p>2. Pull down the tensioner and L-bracket together. Make sure the tiny metal bar is at the center of the groove. Mark the location of holes.</p>  <p>Metal bar</p>	<p>3. Mount the L-bracket with screws.</p>  <p>4. Secure the tensioner with the L-bracket at all the time. Both cords should have tension evenly.</p> 
--	--	---

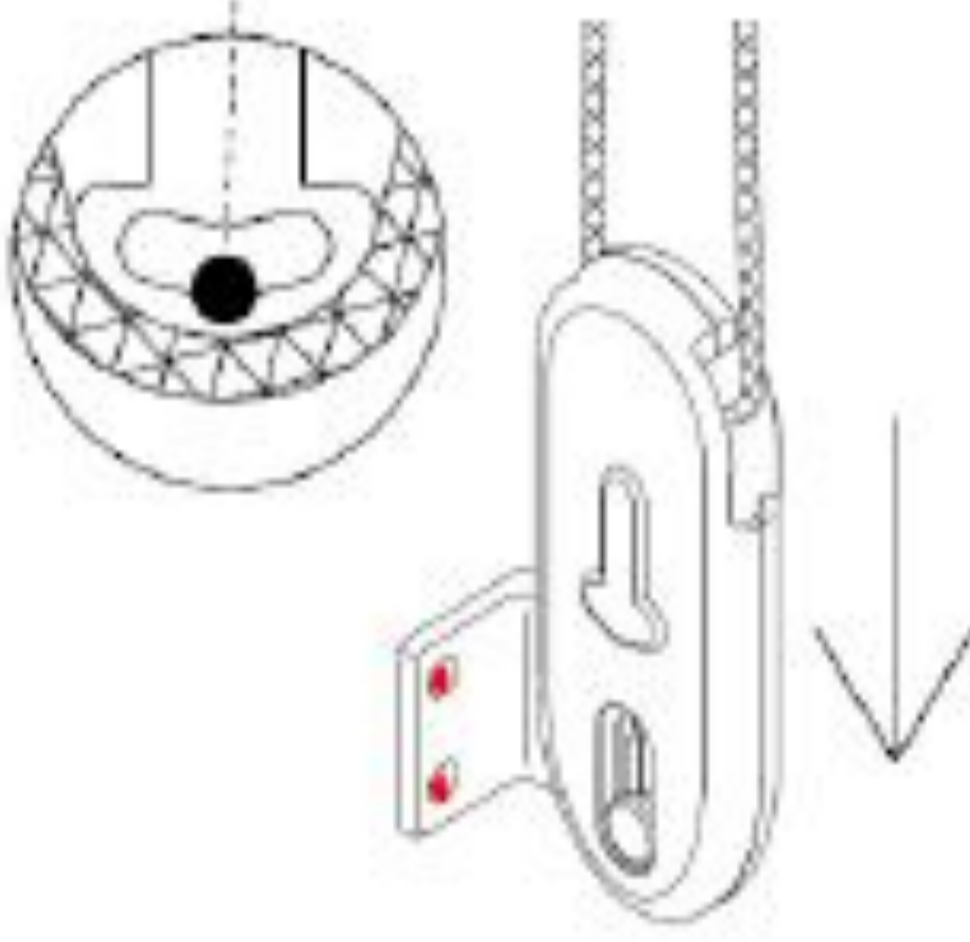
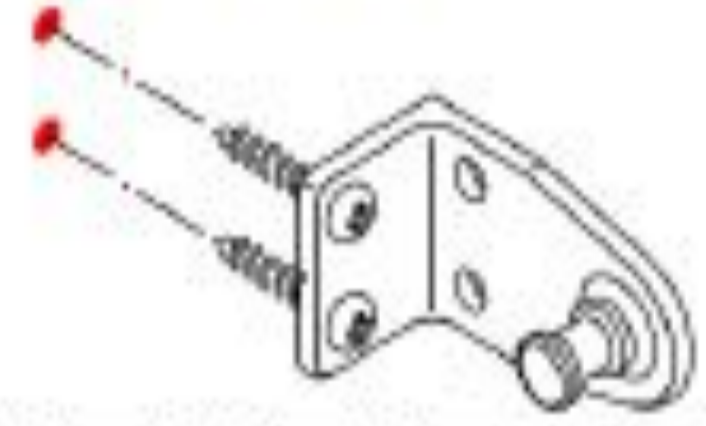
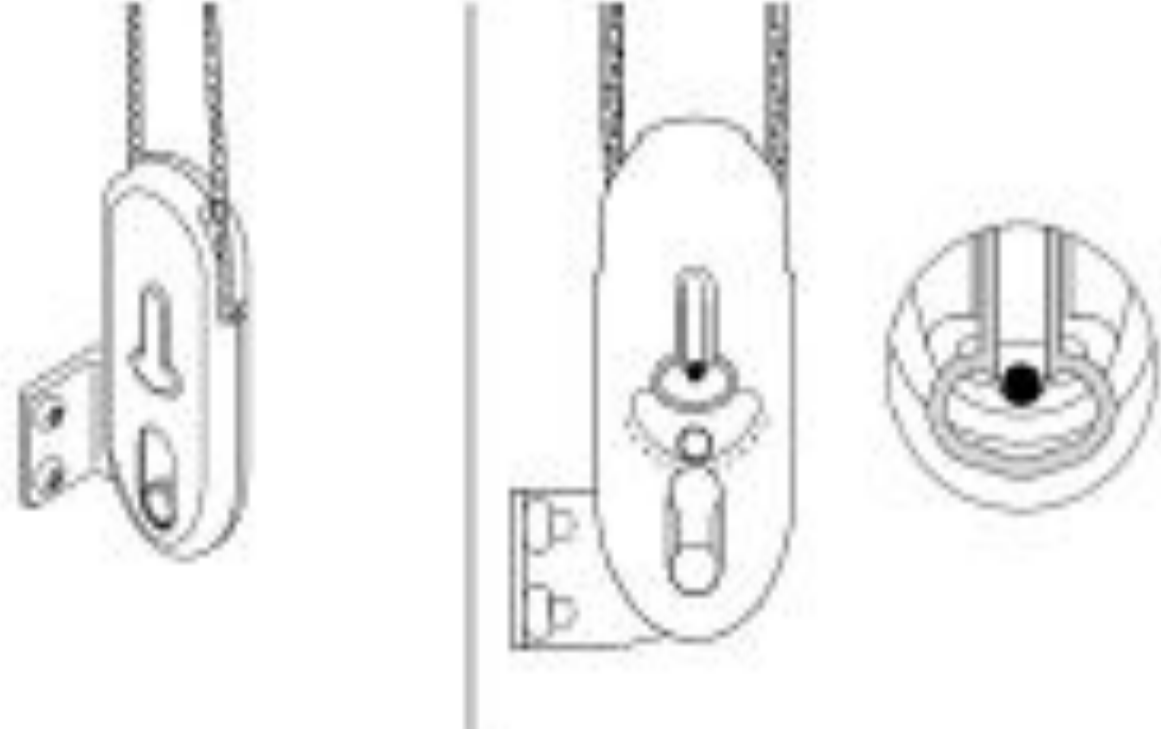

<p>1. Hook the L-bracket to the tensioner.</p> 	<p>2. Pull down the tensioner and L-bracket together. Make sure the tiny metal bar is at the center of the groove. Mark the location of holes.</p>  <p>Metal bar</p>	<p>3. Mount the L-bracket with screws.</p>  <p>4. Secure the tensioner with the L-bracket at all the time. Both cords should have tension evenly.</p> 
--	--	--

- The tensioner and L-bracket must installed properly before operating the clutch shade.
- For safety reasons, avoid having a loose cord. An incorrectly installed tensioner can lead to serious accidents. Below is an example of an incorrectly installed tensioner - the cord is loose and has no tension.



WARNING

ADVERTENCIA



Window Blind Cord Strangulation Risk

A damaged, loose, or missing tension device poses a strangulation risk to children. Remove from use and repair or replace if tension device is damaged, loose, or missing.

Riesgo de estrangulamiento por cordón de persiana

Un dispositivo de tensión dañado, suelto o faltante presenta un riesgo de estrangulamiento para niños. Retire y repare o reemplaza si el dispositivo de tensión está dañado, suelto o falta.

08/2022 ANSI/WCMA 5.1.1

